

First Order RC Filters

High-pass RC filter

$$\omega = 2\pi f$$

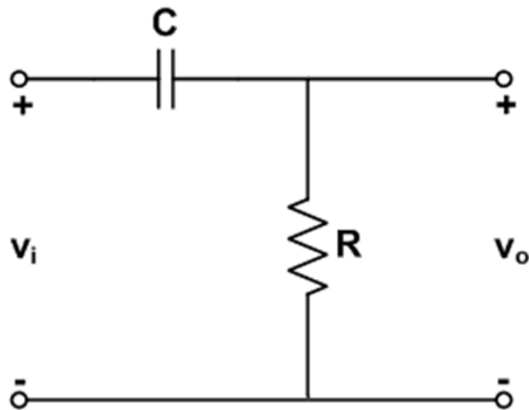

For the circuit on the left, let us calculate the voltage gain $A = v_o/v_i$. However as the impedance of the capacitor changes with the frequency the gain changes with the frequency.

$$A(\omega) = \frac{v_o}{v_i} = \frac{R}{R + Z_C} = \frac{1}{1 + \frac{Z_C}{R}} = \frac{1}{1 - j\frac{1}{\omega CR}}$$

$A(\omega)$ is called **frequency response** of the filter circuit above. As the frequency response $A(\omega)$ is complex, it has a magnitude and phase.

Thus, $A(\omega)$ is called the **frequency response**, $|A(\omega)|$ is called the **magnitude response** and $\angle A(\omega)$ is called the **phase response**.

$$|A(\omega)| = \frac{1}{\sqrt{1 + \frac{1}{\omega^2 R^2 C^2}}}$$

$$\angle A(\omega) = \arctan\left(\frac{1}{\omega RC}\right)$$

$$A(\omega) = |A(\omega)| e^{j\angle A(\omega)}$$

The frequency where the output power drops to half (of the maximum output power) is called the **cut-off frequency, ω_c** . Thus, at the cut-off frequency, the output voltage gain magnitude square will drop to half. As, in this case the maximum gain is one,

$$|A(\omega_c)|^2 = \frac{1}{2} \quad \Rightarrow \quad |A(\omega_c)| = \frac{1}{\sqrt{2}}$$

So, let us calculate the cut-off frequency ω_c for the high-pass circuit on the previous slide.

$$|A(\omega_c)|^2 = \frac{1}{1 + \frac{1}{\omega_c^2 R^2 C^2}} = \frac{1}{2} \quad \Rightarrow \quad \boxed{\omega_c = \frac{1}{RC}} \quad \omega_c = 2\pi f_c$$

Thus, frequency response of the high-pass filter $\mathbf{A}(\omega)$ is given by

$$\boxed{A(\omega) = \frac{1}{1 - j \frac{\omega_c}{\omega}}}$$

$$|A(\omega)| = \frac{1}{\sqrt{1 + \frac{\omega_c^2}{\omega^2}}} \quad \angle A(\omega) = \arctan\left(\frac{\omega_c}{\omega}\right)$$

High-pass RC filter Magnitude and Phase Response

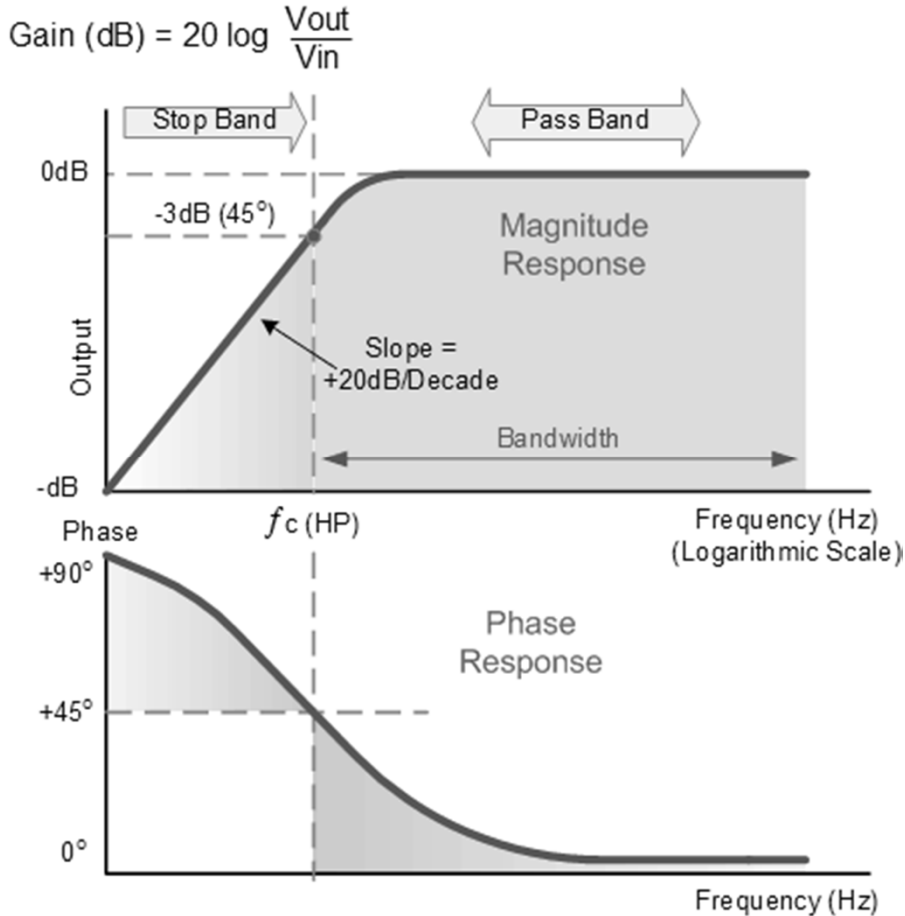

Low-pass RC filter

$$\omega = 2\pi f$$

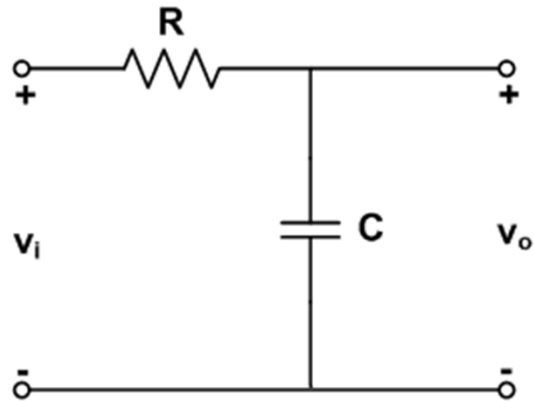

For the circuit on the left, let us calculate the voltage gain $A = v_o/v_i$. However as the impedance of the capacitor changes with the frequency the gain changes with the frequency.

$$A(\omega) = \frac{v_o}{v_i} = \frac{Z_C}{Z_C + R} = \frac{1}{1 + \frac{R}{Z_C}} = \frac{1}{1 + j\omega CR}$$

$A(\omega)$ is called **frequency response** of the filter circuit above. As the frequency response $A(\omega)$ is complex, it has a magnitude and phase.

Thus, $A(\omega)$ is called the **frequency response**, $|A(\omega)|$ is called the **magnitude response** and $\angle A(\omega)$ is called the **phase response**.

$$|A(\omega)| = \frac{1}{\sqrt{1 + \omega^2 R^2 C^2}}$$

$$\angle A(\omega) = -\arctan(\omega RC)$$

$$A(\omega) = |A(\omega)| e^{j\angle A(\omega)}$$

The frequency where the output power drops to half (of the maximum output power) is called the **cut-off frequency, ω_c** . Thus, at the cut-off frequency, the output voltage gain magnitude square will drop to half. As, in this case the maximum gain is one,

$$|A(\omega_c)|^2 = \frac{1}{2} \quad \Rightarrow \quad |A(\omega_c)| = \frac{1}{\sqrt{2}}$$

So, let us calculate the cut-off frequency ω_c for the low-pass circuit on the previous slide.

$$|A(\omega_c)|^2 = \frac{1}{1 + \omega_c^2 R^2 C^2} = \frac{1}{2} \quad \Rightarrow \quad \boxed{\omega_c = \frac{1}{RC}} \quad \omega_c = 2\pi f_c$$

Thus, frequency response of the low-pass filter $\mathbf{A}(\omega)$ is given by

$$\boxed{A(\omega) = \frac{1}{1 + j\frac{\omega}{\omega_c}}}$$

$$|A(\omega)| = \frac{1}{\sqrt{1 + \frac{\omega^2}{\omega_c^2}}} \quad \angle A(\omega) = -\arctan\left(\frac{\omega}{\omega_c}\right)$$

Low-pass RC filter Magnitude and Phase Response

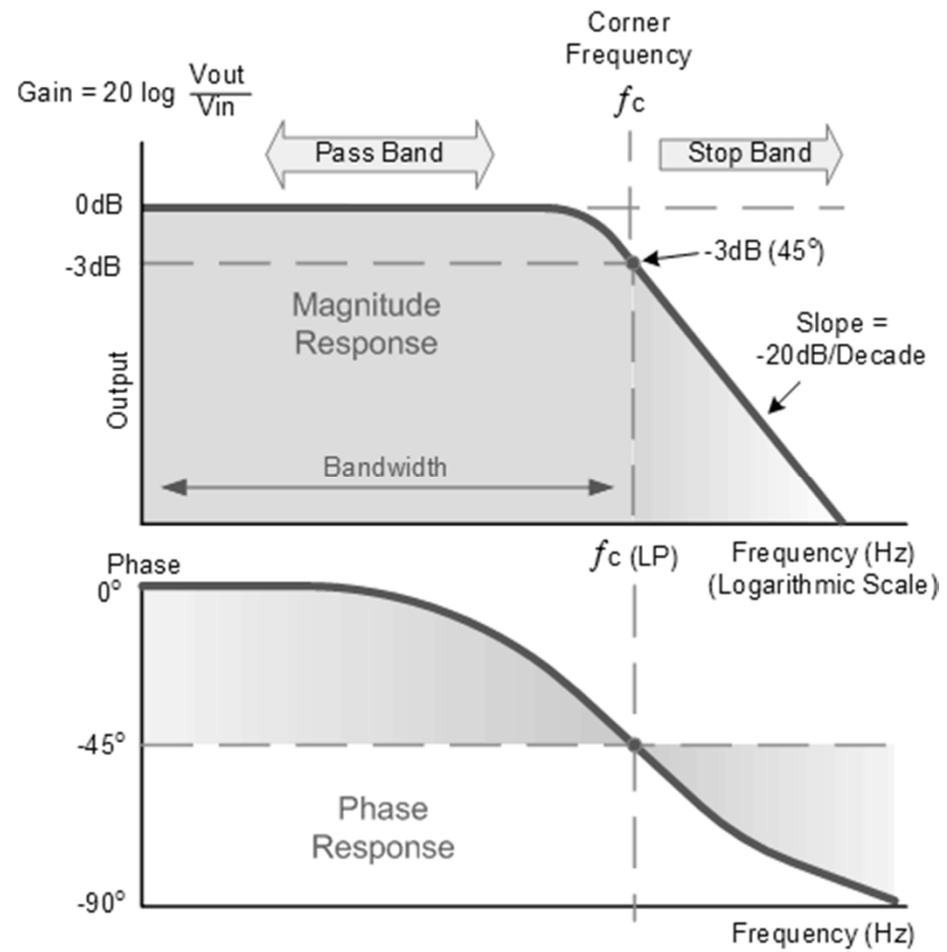

dB (Decibels)

The **decibel (dB)** is a logarithmic unit used to express the ratio of two values of a physical quantity, often power or intensity. One of these values is often a standard reference value, in which case the **decibel** is used to express the level of the other value relative to this reference.

Magnitude response in decibels is given by

$$\text{dB} (|A(\omega)|) = 20 \log_{10} |A(\omega)|$$

And the **scaled magnitude response** (maximum value is 1) in decibels is given by

$$\text{dB} \left(\frac{|A(\omega)|}{\max |A(\omega)|} \right) = 20 \log_{10} \frac{|A(\omega)|}{\max |A(\omega)|}$$

So, the **cut-off frequency for the scaled magnitude response** is $1/\sqrt{2}$. Thus, in dBs:

$$\text{dB} \left(\frac{|A(\omega_c)|}{\max |A(\omega)|} \right) = 20 \log_{10} \frac{1}{2} = -3 \text{ dB.}$$

General Frequency Considerations

Frequency response of an amplifier refers to the frequency range in which the amplifier will operate with negligible effects from capacitors and capacitance in devices.

This range of frequencies can be called the mid-range.

At frequencies above and below the midrange, capacitance and any inductance will affect the gain of the amplifier.

At low frequencies the coupling and bypass capacitors will lower the gain.

At high frequencies stray capacitances associated with the active device will lower the gain.

Also cascading amplifiers will limit the gain at high and low frequencies.