

ELE 361

Electric Machines I

<http://www.ee.hacettepe.edu.tr/~usezen/ele361/>

Textbooks

- A.E. Fitzgerald, C. Kingsley, S.D. Umans, *Electric Machinery*, McGraw-Hill, 6th Ed., 2003, (5th Ed. 1991)
- S.J. Chapman, *Electric Machinery Fundamentals*, McGraw-Hill, 2nd Ed., 1991 (3rd Ed., 1993)
- G.R. Slemon, A. Straughen, *Electric Machines*, Addison Wesley, 1980.
- P.C. Sen, *Principles of Electrical Machinery and Power Electronics*, J. Wiley, 1989
- S.A. Nasar, L.E. Unnewehr, *Electromechanics and Electric Machines*, J. Wiley, 2nd Ed., 1983.

Contents

- **Basic concepts of magnetic circuits (Ch.1, Text 1)**
 - magnetization, energy storage, hysteresis and eddy-current losses
- **Single-phase transformers (Ch.2, Text 1)**
 - equivalent circuit, open-and short circuit tests, regulation, efficiency
- **Electromechanical energy conversion (Ch.3, Text 1)**
 - field energy, co-energy, force, torque, singly and doubly-excited systems
- **Principles of rotating machines (Ch.4, Text 1)**
 - Construction and types of rotating machines, induced emf, armature mmf, torque production
- **Direct-current machines (Ch.7, Text 1)**
 - emf and torque production, magnetization characteristic, methods of excitation, DC generator and motor analysis, ratings and efficiency
- **Single-phase induction motors (Ch.9, Text 1)**
 - equivalent-circuit, s/s operation, starting. linear induction motor, split-phase, capacitor type, shaded pole motors

I. Basic concepts of Magnetic Circuits (M.C.)

1. Basic principles

- Electromechanical energy conversion device (E.M.D)
 - links electrical & mechanical systems
- or Electromechanical transducer (E.M.T)
 - converts electrical energy to mechanical energy and vice versa

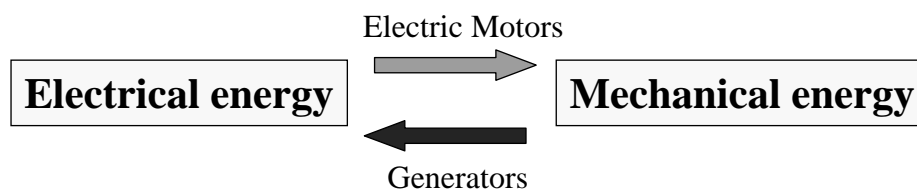

- The energy conversion is reversible

- Most energy forms are converted to electrical energy, since it can be
 - transmitted & distributed easily
 - controlled efficiently and reliably in a simple manner

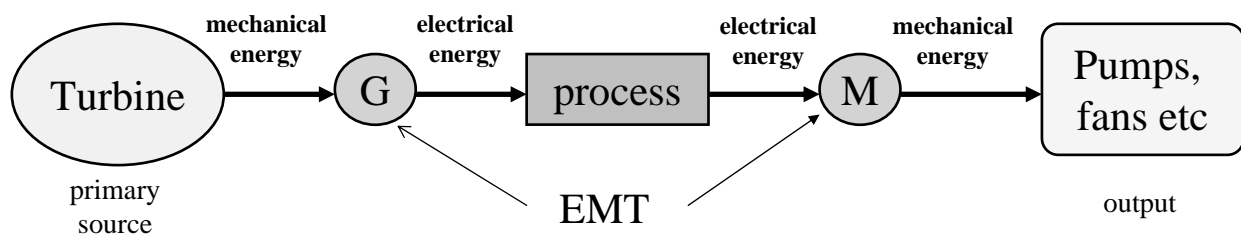
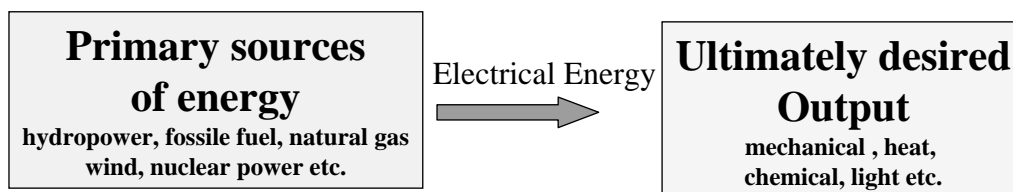

- Coupling between electrical systems and mechanical systems is through the medium of **fields of electric currents or charges.**

- MAGNETIC FIELDS

- Electromagnetic machine

- ELECTROSTATIC FIELDS

- Electrostatic machine (not used in practice due to low power densities, resulting in large m/c sizes)

Principle phenomena in Electromechanical Energy Conversion (E.M.C)

1. Force on a conductor
2. Force on ferromagnetic materials
(e.g. iron)
3. Generation of voltage

Force on a conductor

- A mechanical force is exerted on current carrying conductor in a magnetic field (MF) and also between current carrying conductors by means of their MF
 - Reversibly voltage is induced in a circuit undergoing motion in a MF

$$\vec{F} = l \vec{i} \times \vec{B}$$

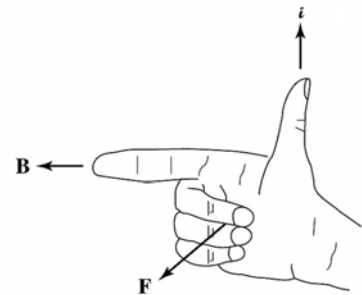

Right-hand rule

NB. In left-hand rule, B and i exchange fingers

Ex1.

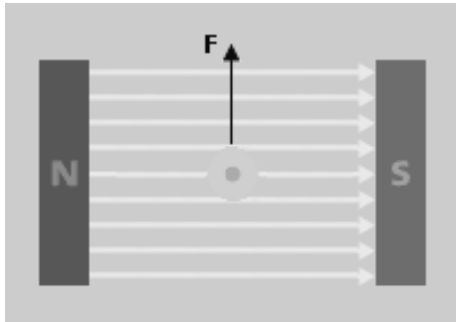

Ex3.

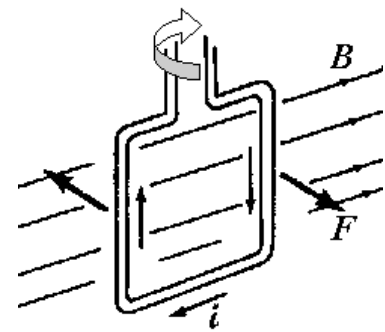

Ex2.

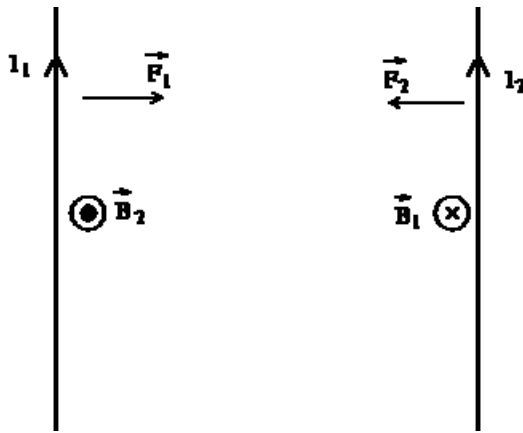

Ex4.

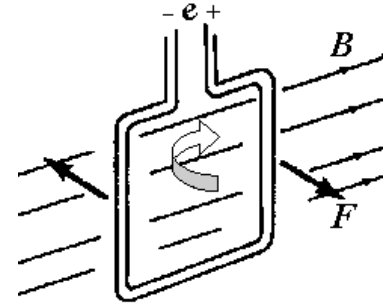

Induced voltage $e = \frac{d\lambda}{dt}$

$\lambda(t)$ = flux linkage

Force on a ferromagnetic materials

- A mechanical force is exerted on a ferromagnetic material tending to align it with the position of the densest part of MF.

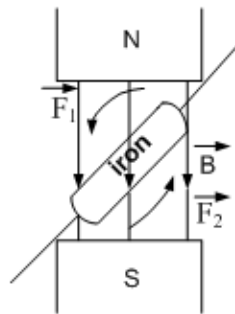

Generation of voltage

- A voltage is induced in a coil when there is a change in the flux linking the coil

$$e = N \frac{d\phi}{dt} = \frac{d\lambda}{dt}$$

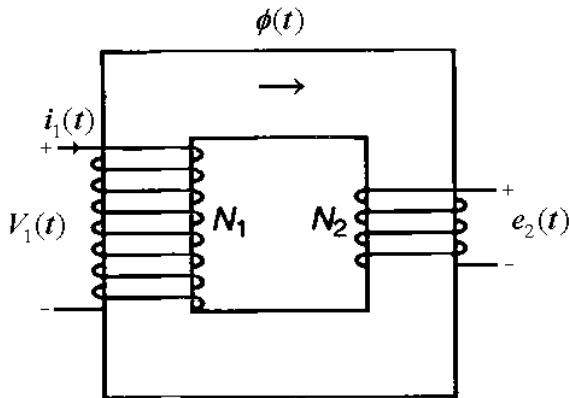

$$e_2 = N_2 \frac{d\phi}{dt}$$

$$\mu_{\text{iron}} \gg \mu_{\text{air}}$$

- The change in flux linkage is either due to changing flux linking the coil (i.e. transformer voltage) or by relative motion of coil and MF with respect each other

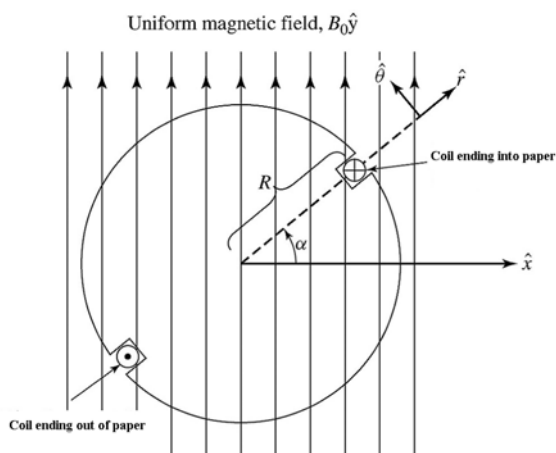

Single-coil rotor

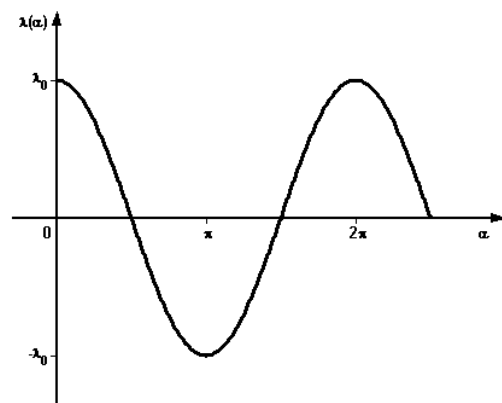

**Flux linkage of the coil
(i.e. flux captured by the coil)**

$$\lambda(\alpha) = NB_0 A \cos(\alpha), \quad \alpha = \omega t$$

Classification of E.M.D.

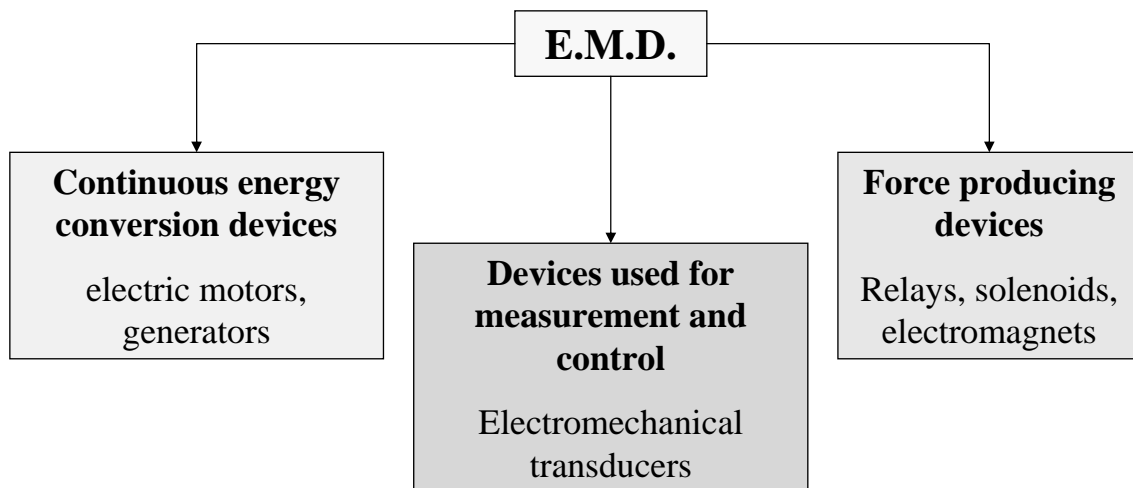

An E.M.D involves energy in 4 forms:

- **Motoring action**

$$\left(\begin{array}{c} \text{Energy input from} \\ \text{electrical sources} \end{array} \right) = \left(\begin{array}{c} \text{Mechanical} \\ \text{energy output} \end{array} \right) + \left(\begin{array}{c} \text{Energy converted} \\ \text{into heat due to losses} \end{array} \right) + \left(\begin{array}{c} \text{Increase in energy} \\ \text{stored in magnetic field} \end{array} \right)$$

- **Generating action**

$$\left(\begin{array}{c} \text{Electrical energy} \\ \text{output} \end{array} \right) = \left(\begin{array}{c} \text{Mechanical} \\ \text{energy input} \end{array} \right) - \left(\begin{array}{c} \text{Energy converted} \\ \text{into heat due to losses} \end{array} \right) - \left(\begin{array}{c} \text{Increase in energy} \\ \text{stored in magnetic field} \end{array} \right)$$

Irreversible conversion to heat occurs due to

{	<ul style="list-style-type: none">– heat in i^2R losses (copper losses)– magnetic losses (core losses)– mechanical losses (friction & windage losses)
---	--

Rewriting the energy balance equation (motoring convention):

$$\underbrace{\left(\begin{array}{c} \text{Electrical energy input} \\ - \\ \text{Copper losses} \end{array} \right)}_{\text{Net electrical energy input}} = \underbrace{\left(\begin{array}{c} \text{Mechanical energy output} \\ + \\ \text{Friction \& windage losses} \end{array} \right)}_{\text{Gross mechanical energy output}} + \left(\begin{array}{c} \text{Increasing energy stored in M.F.} \\ + \\ \text{Core losses} \end{array} \right)$$

2. Analysis of Magnetic Circuits (M.C.)

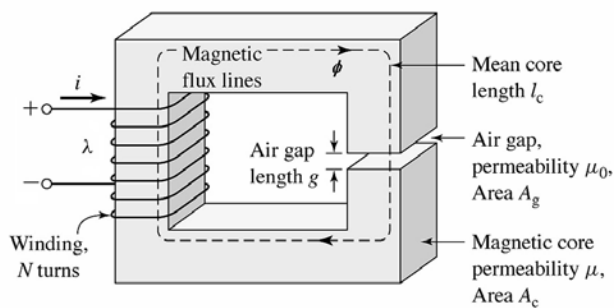

$$g \ll l_c$$

$$\mu_c \gg \mu_{air} \approx \mu_0$$

$$\mu_0 = 4\pi \times 10^{-7} \text{ H/m}$$

$$\mu_c = \mu_r \mu_0$$

$$2000 < \mu_r < 80000$$

Magnetomotive force (\mathcal{F}): $\mathcal{F} = Ni$ [Ampere-turns (AT)]

Core flux density (B_c): $B_c = \frac{\phi}{A_c}$ [Wb/m² or Tesla (T)]

Airgap flux density (B_g): $B_g = \frac{\phi}{A_g}$ [Wb/m² or Tesla (T)]

where ϕ represents the magnetic flux

Fringing effects:

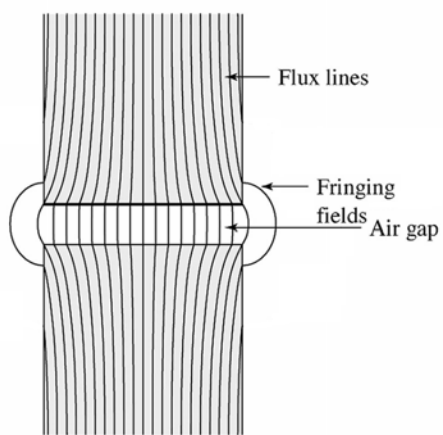

Due to fringing effects

$$A_g > A_c$$

Normally, we ignore fringing effects, so

$$A_g \cong A_c$$

$$\text{Since } A_g \cong A_c \Rightarrow B_g \cong B_c$$

Magnetomotive Force

$$\mathcal{F} = \oint_C \vec{H} \cdot d\vec{\ell}$$

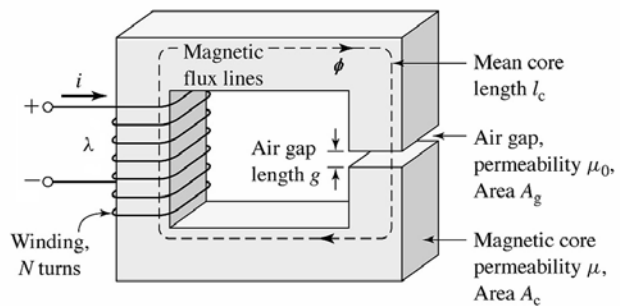

For the M.C. on the right

$$\mathcal{F} = \sum Hl = H_c l_c + H_g g = Ni$$

where H represents the magnetic field intensity

Relationship between B_c and H_c

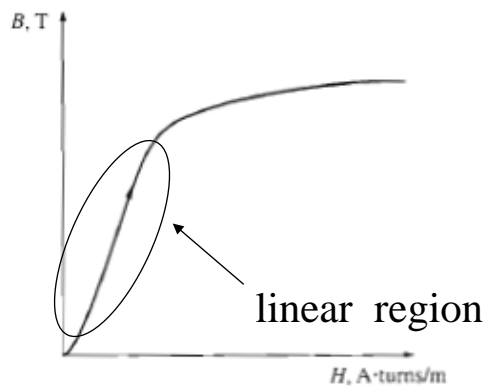

In the linear region

$$B_c \cong \mu_c H_c$$

$$B_c \propto \phi, H_c \propto \mathcal{F}$$

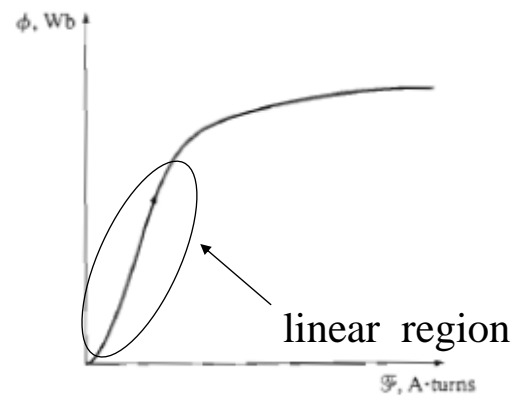

$$\mathcal{F} = H_c l_c + H_g g$$

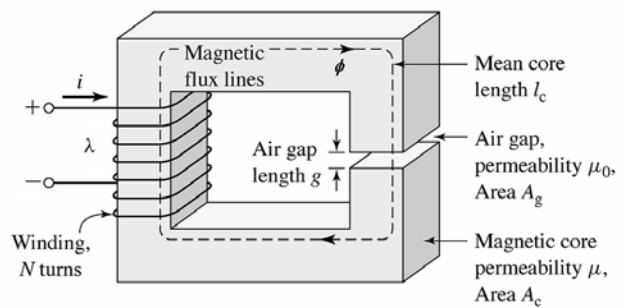

Assuming operating in the linear region, we can rewrite the above equation as :

$$\mathcal{F} = \frac{B_c}{\mu_c} l_c + \frac{B_g}{\mu_0} g$$

Magnetomotive Force - 2

$$\mathcal{F} = \frac{B_c}{\mu_c} \ell_c + \frac{B_g}{\mu_0} g$$

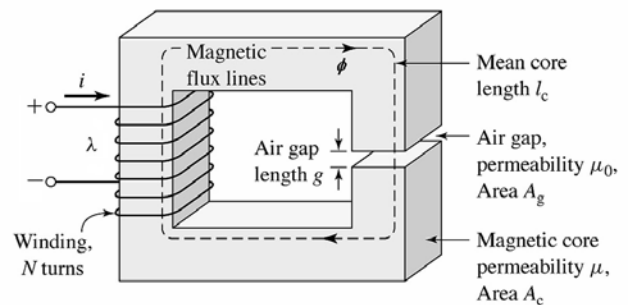

Noting that $B = \phi/A$, we can rewrite the above equation as

$$\mathcal{F} = \frac{\phi}{\mu_c A_c} \ell_c + \frac{\phi}{\mu_0 A_g} g \quad \Rightarrow \quad \mathcal{F} = \phi \left(\frac{\ell_c}{\mu_c A_c} + \frac{g}{\mu_0 A_g} \right)$$

We can further simplify the notation

$$\mathcal{F} = \phi (\mathcal{R}_c + \mathcal{R}_g) \quad \text{where } \mathcal{R} \text{ represents the magnetic resistance of the medium against flux, called } \mathbf{reluctance}$$

Reluctance

$$\mathcal{F} = \phi(\mathcal{R}_c + \mathcal{R}_g)$$

where:

$$\mathcal{R}_c = \frac{l_c}{\mu_c A_c} \quad \text{and} \quad \mathcal{R}_g = \frac{g}{\mu_0 A_g} \quad [\text{AT/Wb}]$$

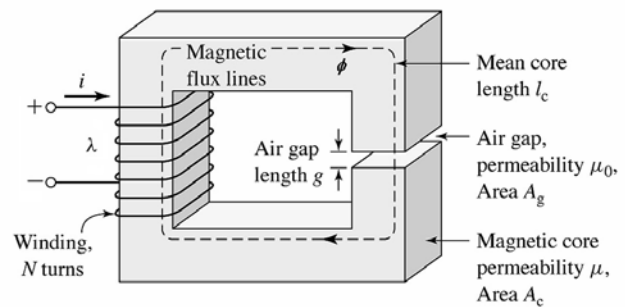

Magnetic resistance of a medium against magnetic flux is called RELUCTANCE

Note the analogy between the electrical circuits

$$\mathcal{F} = \phi(\mathcal{R}_c + \mathcal{R}_g) \quad \Leftrightarrow \quad V = i(R_1 + R_2)$$

Analogy between electric and magnetic circuits

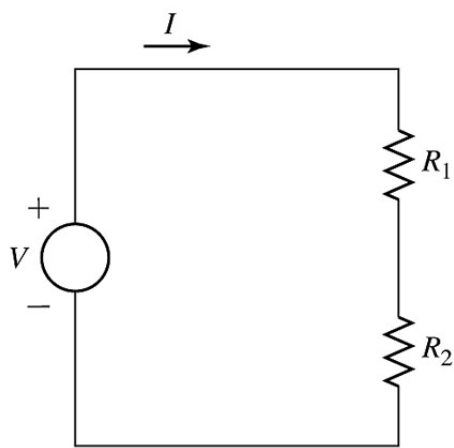

$$I = \frac{V}{(R_1 + R_2)}$$

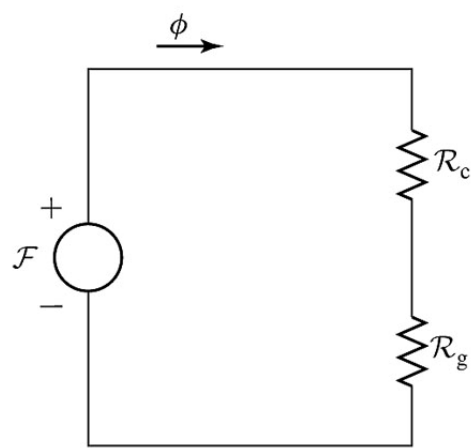

$$\phi = \frac{\mathcal{F}}{(\mathcal{R}_c + \mathcal{R}_g)}$$

Correspondence of conductance in magnetic circuits is called permeance:

$$\mathcal{P} = \frac{1}{\mathcal{R}}$$

Simplifications:

$$\mathcal{F} = \phi(\mathcal{R}_c + \mathcal{R}_g)$$

$$\mathcal{R}_c = \frac{l_c}{\mu_c A_c} \quad \mathcal{R}_g = \frac{g}{\mu_0 A_g}$$

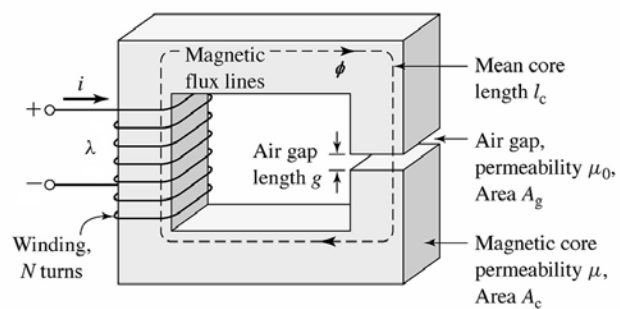

Noting that $\mu_c = \mu_r \mu_0$ and $2000 < \mu_r < 80000$

$$\mathcal{R}_c \ll \mathcal{R}_g \quad \text{in the linear region of } B_c\text{-}H_c \text{ curve, i.e. in linear M.C.s}$$

so

$$\mathcal{F} \cong \phi \mathcal{R}_g \quad \Rightarrow \quad \phi \cong \frac{\mathcal{F}}{\mathcal{R}_g} = \frac{Ni}{\mathcal{R}_g} = \frac{Ni \mu_0 A_c}{g}$$

Nearly all magnetomotive force (\mathcal{F}) is used to overcome the airgap portion of the MC

3. Flux Linkage and Inductance

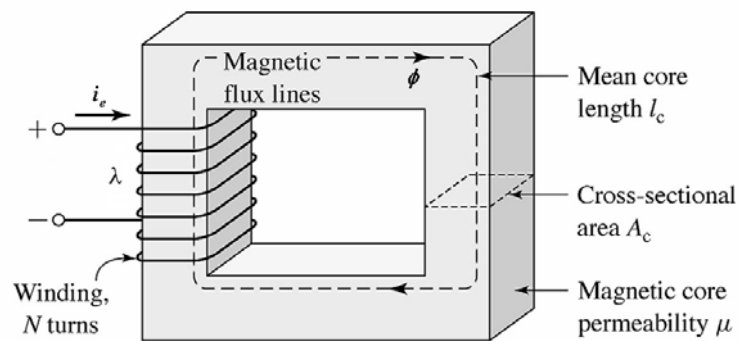

Flux linkage $\lambda = N\phi$ and induced voltage e is given by $e = \frac{d\lambda}{dt}$

For linear magnetic circuits $\lambda = Li$
where L indicates the self-inductance of coil

Self inductance of the N-turn coil:

$$\lambda = N\phi = Li$$

$$\Rightarrow L = \frac{N\phi}{i} = \frac{NB_c A_c}{i}$$

$$\text{or } L = \frac{N\phi}{i} = \frac{N\mathcal{F}}{i\mathcal{R}_c} = \frac{N^2}{\mathcal{R}_c}$$

$$L = N^2 \mathcal{P}_c$$

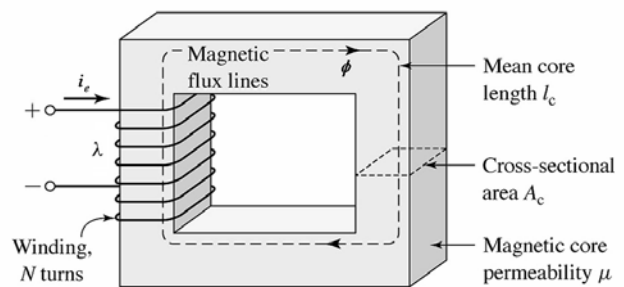

For non-linear magnetic circuits

$$L = \frac{d\lambda}{di} = N \frac{d\phi}{di}$$

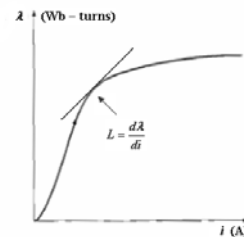

Ex1.

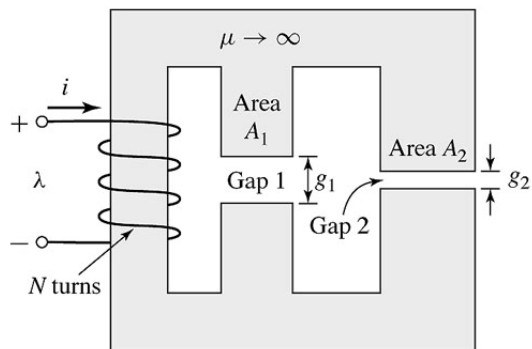

Find:

- a) the inductance of the winding
- b) flux density in gap g_1 (B_1)

Equivalent magnetic circuit:

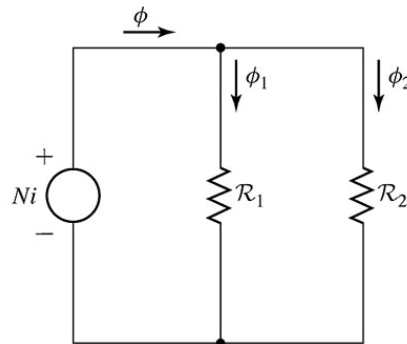

Ex2.

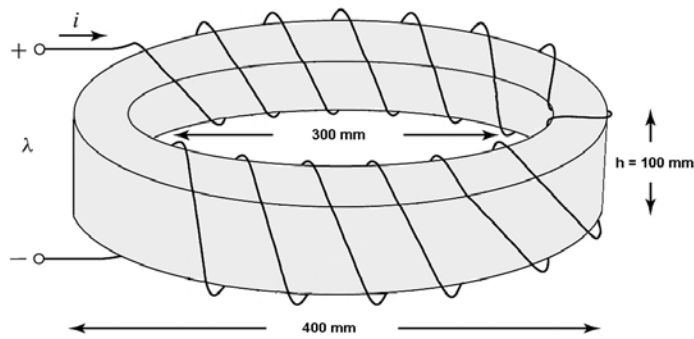

$$\mu_{\text{plastic}} = \mu_0$$
$$N = 200 \text{ turns}$$
$$i = 50 \text{ A}$$

Consider the plastic ring above and assuming rectangular cross section area

- Find B at the mean diameter of coil
- Find inductance of coil, assuming flux density inside ring is uniform

Self and Mutual Inductances

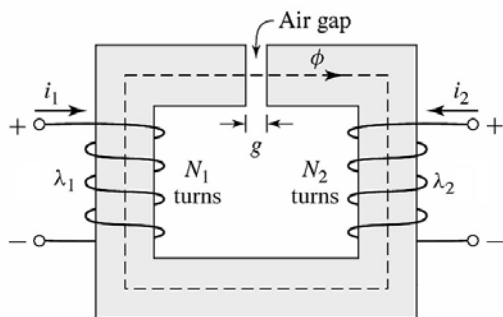

$$\lambda_1 = N_1 \phi \quad \mathcal{F}_1 = N_1 i_1$$

$$\lambda_2 = N_2 \phi \quad \mathcal{F}_2 = N_2 i_2$$

$$\phi = \frac{\mathcal{F}_1 + \mathcal{F}_2}{\mathcal{R}_g + \mathcal{R}_c} \cong \frac{\mathcal{F}_1 + \mathcal{F}_2}{\mathcal{R}_g}$$

Assumption: $\mu_c \gg \mu_{air} \approx \mu_0$

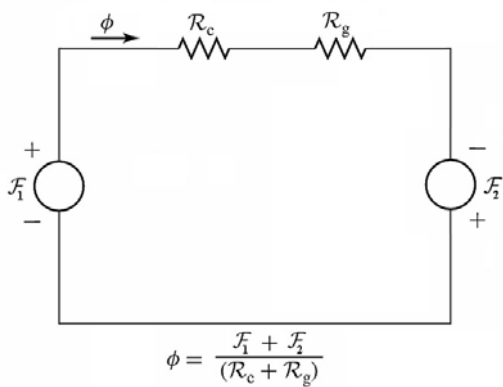

$$\lambda_1 = \frac{N_1 N_1 i_1}{\mathcal{R}_g} + \frac{N_1 N_2 i_2}{\mathcal{R}_g}$$

$$\lambda_1 = \underbrace{\frac{N_1^2 \mu_0 A_g}{g}}_{L_{11}} i_1 + \underbrace{\frac{N_1 N_2 \mu_0 A_g}{g}}_{L_{12}} i_2$$

Self-inductance of coil

Mutual-inductance between coils 1 & 2

Self and Mutual Inductances - 2

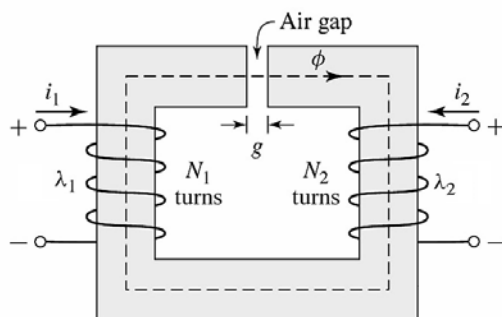

$$\lambda_1 = L_{11}i_1 + L_{12}i_2$$

$$\lambda_2 = L_{21}i_1 + L_{22}i_2$$

$$L_{11} = N_1^2 \mathcal{P}_g$$

$$L_{22} = N_2^2 \mathcal{P}_g$$

$$L_{12} = L_{21} = N_1 N_2 \mathcal{P}_g$$

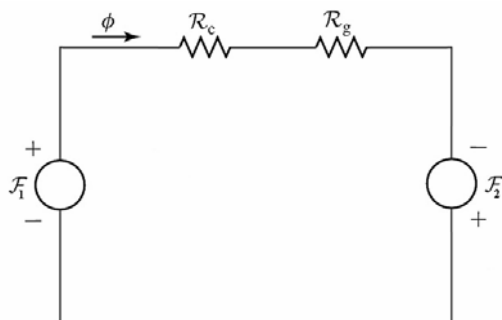

where
$$\mathcal{P}_g = \frac{1}{\mathcal{R}_g} = \frac{\mu_0 A_g}{g}$$

Leakage Flux

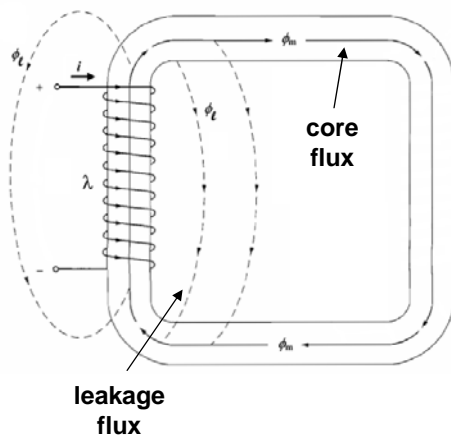

$$\phi = \phi_l + \phi_m$$

Leakage flux: ϕ_l

Magnetizing flux:
(core flux) ϕ_m

Not all the flux closes its path from the magnetic core, but some portion closes its path through air.

This is called the leakage flux, ϕ_l .

4. Magnetic Stored Energy

- Stored energy in a magnetic circuit in a time interval between t_1 and t_2 :

$$\Delta W = \int_{t_1}^{t_2} p \, dt$$

$$p = e i$$

$$= \int_{t_1}^{t_2} e i \, dt$$

$$e = N \frac{d\phi}{dt} = \frac{d\lambda}{dt}$$

$$= \int_{t_1}^{t_2} \frac{d\lambda}{dt} i \, dt$$

$$\Delta W = \int_{\lambda_1}^{\lambda_2} i \, d\lambda$$

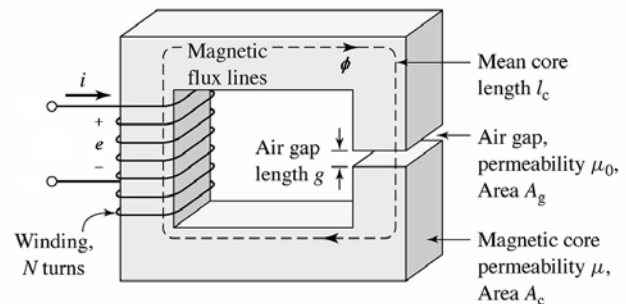

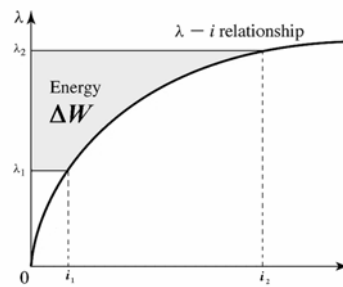
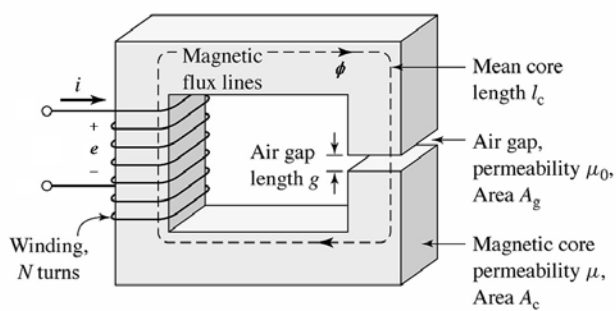

$$\Delta W = \int_{\lambda_1}^{\lambda_2} i \, d\lambda$$

For a linear magnetic circuit:

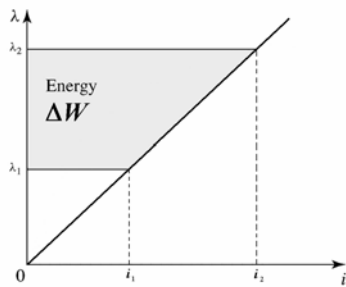

$$\lambda = Li \Rightarrow i = \frac{\lambda}{L}$$

$$\Delta W = \frac{1}{L} \int_{\lambda_1}^{\lambda_2} \lambda \, d\lambda$$

$$\Delta W = \frac{1}{2L} (\lambda_2^2 - \lambda_1^2)$$

Similarly

$$\begin{aligned}\Delta W &= \int_{\lambda_1}^{\lambda_2} i \, d\lambda & \lambda &= L i \Rightarrow d\lambda = L \, di \\ &= L \int_{i_1}^{i_2} i \, di \\ &= \frac{1}{2} L (i_2^2 - i_1^2)\end{aligned}$$

With $i_1 = 0, i_2 = i$ or $\lambda_1 = 0, \lambda_2 = \lambda$

$$\Delta W = \frac{1}{2} L i^2$$

or

$$\Delta W = \frac{1}{2L} \lambda^2$$

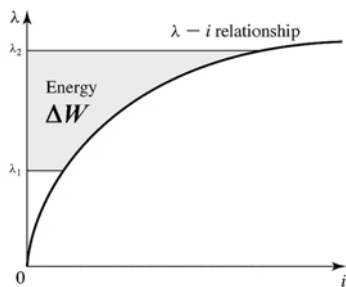

$$\Delta W = \int_{\lambda_1}^{\lambda_2} i \, d\lambda$$

$$\mathcal{F} = N i \Rightarrow i = \frac{\mathcal{F}}{N}$$

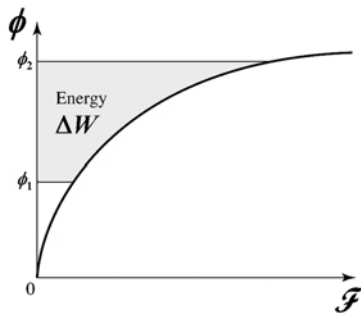

$$\lambda = N \phi \Rightarrow d\lambda = N \, d\phi$$

$$\Delta W = \int_{\phi_1}^{\phi_2} \mathcal{F} \, d\phi$$

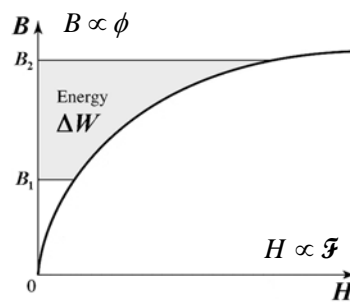

4. Magnetic Materials

- Magnetic
 - Ferrimagnetic ($2000 < \mu_r < 10000$)
 - e.g. Mn-Zn alloy
 - Ferromagnetic (μ_r around 80000)
 - Hard (permanent magnet)
 - e.g. Alnico, Neodimium-Iron-Boron, etc.
(rare-earth magnets)
 - Soft (electrical steel)
 - e.g. FeSi, FeNi and FeCo alloys
- Non-magnetic
 - Paramagnetic (μ_r slightly > 1)
 - e.g. aluminum, platinum and magnesium
 - Diamagnetic (μ_r slightly < 1)
 - e.g. copper and zinc

Properties of Magnetic Materials:

- Become magnetized in the same direction of the applied magnetic field
- B varies nonlinearly with H (double-valued relationship between B and H)
- Exhibit saturation and hysteresis
- Dissipate power under time-varying magnetic fields

Terminology:

- Magnetization curve
- Magnetic hysteresis
- Residual flux density, B_r and coercive field intensity, H_c
- Cyclic state

Magnetic Hysteresis

UNMAGNETIZED

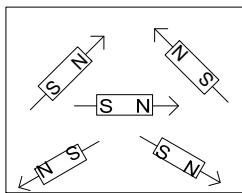

$B=0$

EXTERNAL
MAGNETIZING FORCE

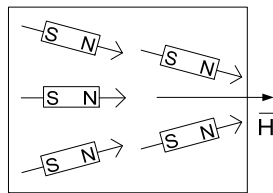

$\mu_c \gg \mu_o$

Domain magnetic moments
tend to align in the direction
of applied field.
- much larger B.

INCREASE
APPLIED FIELD

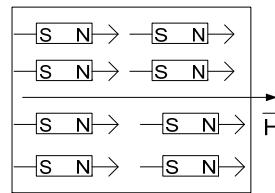

-Material is saturated.
-Further increase in H
(or F) no longer contributes to
increasing B
 $B=B_{max}$

REMOVE EXTERNAL
FIELD

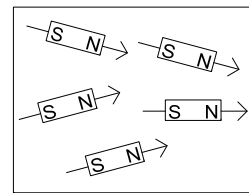

$H \rightarrow 0, B=B_r$

-Magnetic axes naturally align
along certain axes of easy
magnetization
-Not totally random orientation of
magnetic dipole moments
-Not magnetization along the
previously applied field

Magnetic hysteresis

**Normal (DC) magnetization curve (n.m.c)
for a ferromagnetic core:**

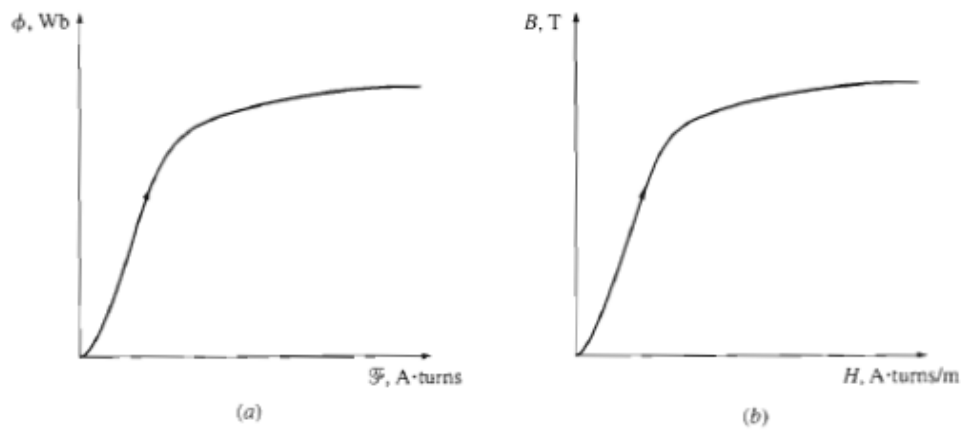

The curve used to describe a magnetic material is called the B-H curve, or the hysteresis loop:

Hysteresis Loop:

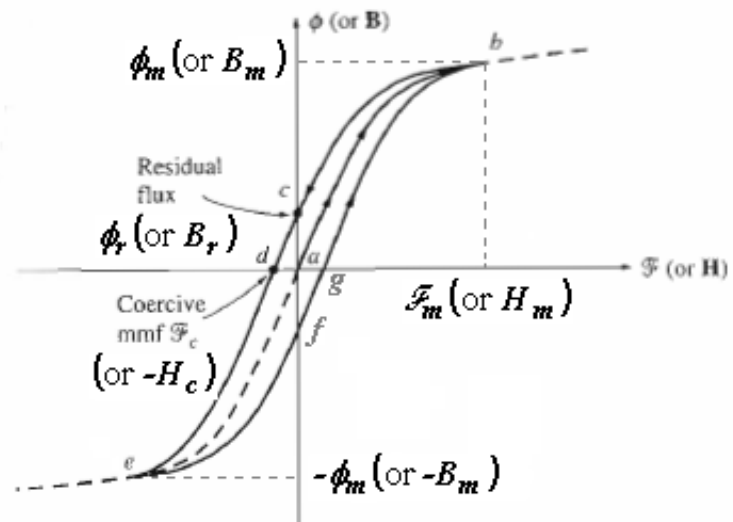

B_r : residual flux density

H_c : coercive field intensity

Hysteresis Loop

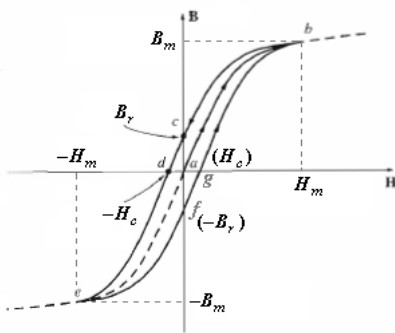

Magnetic performance of magnetic material depends on their previous history

During measurements, the material should be put to a definite magnetic cycle:

H is varied in a cyclic manner
 $\{ +H_m \rightarrow 0 \rightarrow -H_m \rightarrow 0 \rightarrow +H_m \}$

1. From a demagnetized state ($B = 0$) while mmf \mathcal{F} or field intensity H is gradually increased, B moves on n.m.c. from $a \rightarrow b$:
 $[H = 0 \rightarrow H_m \Rightarrow B = 0 \rightarrow B_m]$
2. B moves from $b \rightarrow c$: $[H = H_m \rightarrow 0 \Rightarrow B = B_m \rightarrow B_r]$
3. B moves from $c \rightarrow d$: $[H = 0 \rightarrow -H_c \Rightarrow B = B_r \rightarrow 0]$
4. B moves from $d \rightarrow e$: $[H = -H_c \rightarrow -H_m \Rightarrow B = 0 \rightarrow -B_m]$
5. B moves from $e \rightarrow f$: $[H = -H_m \rightarrow 0 \Rightarrow B = -B_m \rightarrow -B_r]$
6. B moves from $f \rightarrow g$: $[H = 0 \rightarrow H_c \Rightarrow B = -B_r \rightarrow 0]$
7. B moves from $g \rightarrow b$: $[H = H_c \rightarrow H_m \Rightarrow B = 0 \rightarrow B_m]$

Ex:

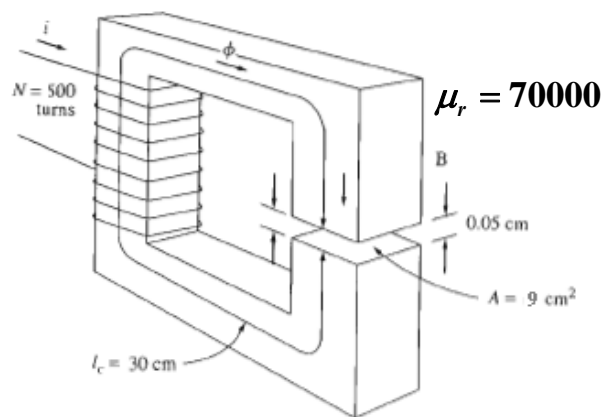

Find:

- The exciting current i_e for $B_c = 1.0$ T.
- The flux ϕ and flux linkage λ (ignore leakage fluxes).
- The reluctance of the airgap \mathcal{R}_g and magnetic core \mathcal{R}_c .
- The induced emf e for a 60 Hz core flux of $B_c = 1.0 \sin 377 t$, Tesla
- The inductance L of the winding (neglect fringing fluxes)
- The magnetic stored energy W at $B_c = 1.0$ T
- Assuming that core material has a DC magnetization curve, find the exciting current i for $B_c = 1.0$ T

Ex:

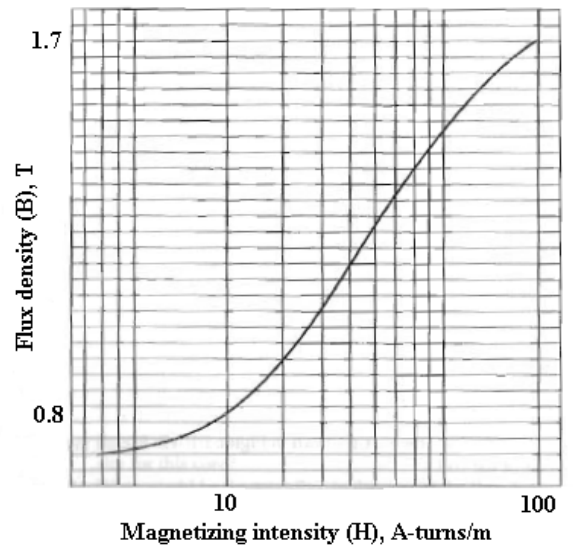
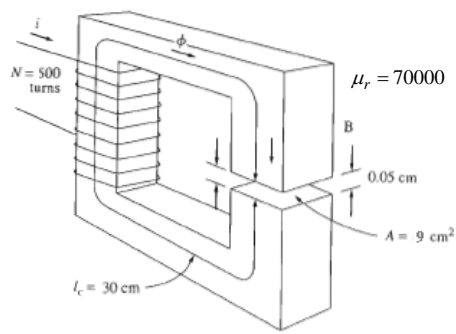

Magnetization curve of the core

6. AC Excitation and Losses

- a) Relation between periodic exciting current i_e and flux ϕ in a magnetic circuit

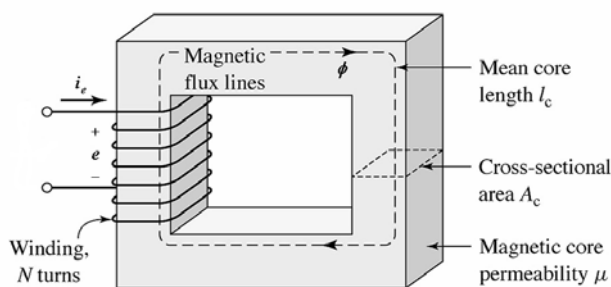

$$v(t) = e(t) = N \frac{d\phi}{dt}$$

$$v(t) = V_m \cos \omega t \quad \text{where } \omega = 2\pi f$$

$$\phi(t) = \Phi_m \sin \omega t$$

$$e(t) = N \frac{d\phi}{dt} = N\omega\Phi_m \cos \omega t = E_m \cos \omega t$$

$$E_m = 2\pi f N \Phi_m \quad E_{rms} = \frac{2\pi}{\sqrt{2}} f N \Phi_m$$

$$E_{rms} = 4.44 f N \Phi_m$$

Due to non-linear $B-H$ characteristic (or $\phi - \mathcal{F}$ ch.) of a magnetic material, the exciting current i_e (or i_ϕ) is a distorted sine wave although flux ϕ is sinusoidal.

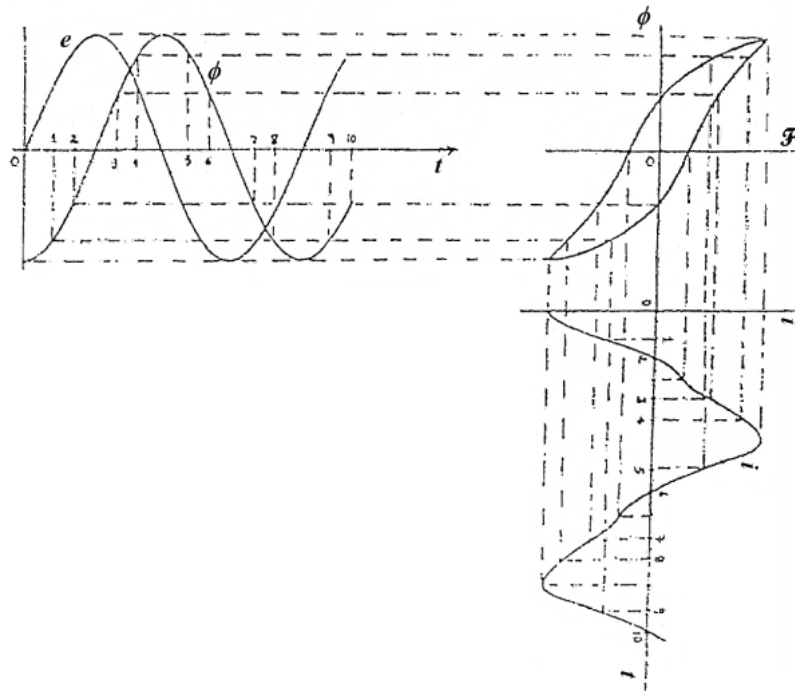

Distorted sine wave exciting current waveform

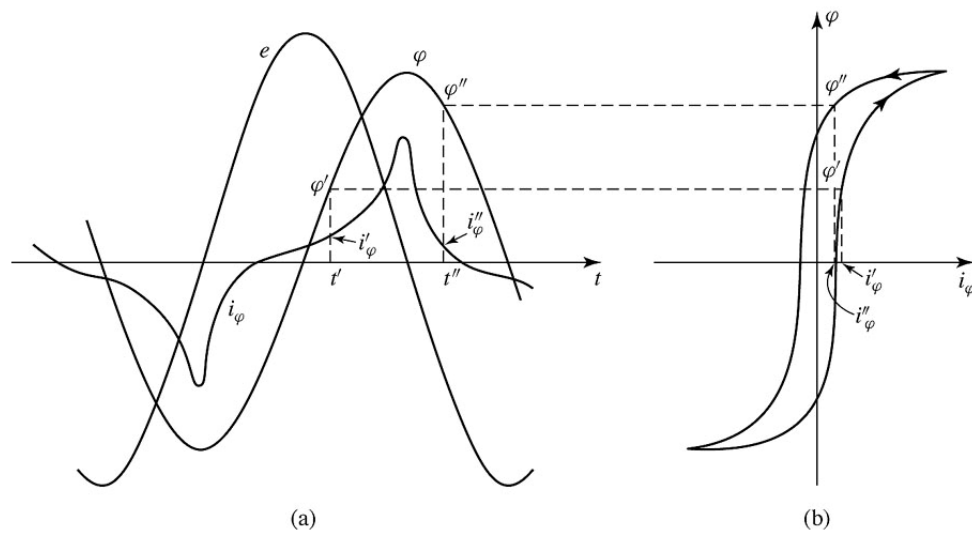

Expanding i_e using Fourier series

$$i_e(t) = I_{c1} \cos \omega t + I_{m1} \sin \omega t + I_{c3} \cos 3\omega t + I_{m3} \sin 3\omega t + I_{c5} \cos 5\omega t + I_{m5} \sin 5\omega t + \dots$$

Neglecting high order harmonics:

$$i_e(t) \cong I_{c1} \cos \omega t + I_{m1} \sin \omega t$$

$$i_e(t) \cong I_c \cos \omega t + I_m \sin \omega t$$

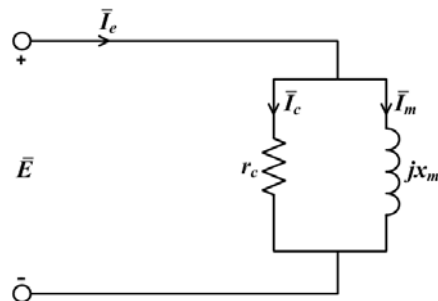

r_c : core loss resistance

x_m : magnetizing reactance

Steady-state equivalent circuit model of the exciting branch

b) Energy (power) losses in magnetic circuits

Power loss in M.C. is due to:

- Hysteresis loss
- Eddy current losses

Hysteresis Loss

$$\Delta W = \int_{\phi_1}^{\phi_2} \mathcal{F} d\phi \quad \mathcal{F} = H_c l_c$$

$$\phi = B_c A_c$$

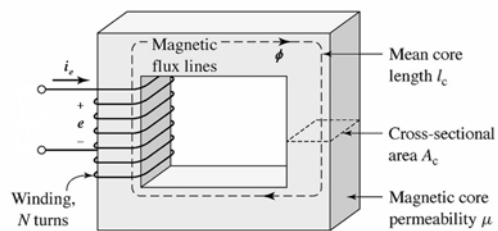

$$\Delta W = A_c l_c \int_{B_1}^{B_2} H dB$$

$$\Delta W = V_c \int_{B_1}^{B_2} H dB$$

V_c : Volume of the magnetic core

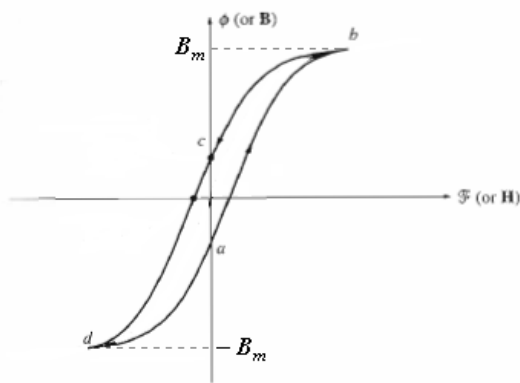

For one cycle of ac excitation:

$$W_{ab} = V_c \int_{B_a}^{B_m} H dB > 0$$

$$W_{bc} = V_c \int_{B_m}^{B_c} H dB < 0$$

$$W_{cd} = V_c \int_{B_c}^{-B_m} H dB > 0$$

$$W_{da} = V_c \int_{-B_m}^{B_a} H dB < 0$$

Hysteresis loss per cycle of ac excitation:

$$W_h = W_{ab} + W_{bc} + W_{cd} + W_{da}$$

$$P_h = W_h f$$

Empirical eqn: $P_h = \eta V_c B_m^x f$

η : constant depending on material type

$$(1.5 \leq x \leq 2.5)$$

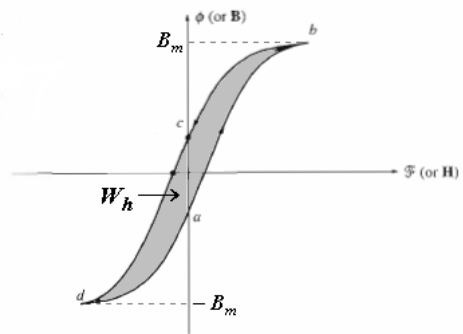

Eddy Current Loss

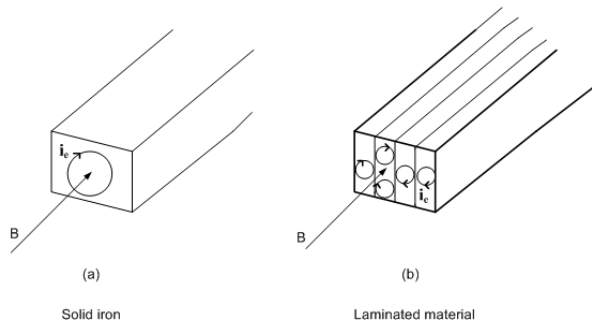

In general, M.C. have

- very high magnetic permeability,

$$\mu_c \gg \mu_{air} \approx \mu_0$$

- high electrical conductivity (low resistivity), which causes extra I^2R losses (P_e) within the magnetic materials when they are subject to time-varying MF.

Eddy current loss:

$$P_e = K_e V_c d^2 B_m^2 f^2$$

Eddy Current Loss

$$P_e = K_e V_c d^2 B_m^2 f^2$$

d : thickness of lamination
 K_e : constant depending on material resistivity ρ

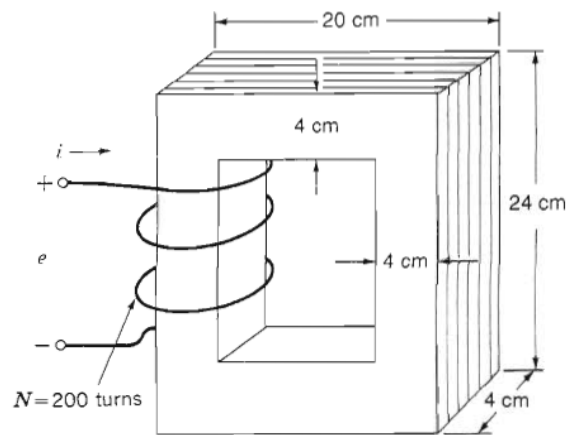

Core loss: $P_{core} = P_h + P_e$

Stacking factor F_s in a laminated material

$$A_{c(\text{effective})} = F_s A_{c(\text{actual})} \quad 0.95 < F_s < 1$$

Core Loss

$$P_{core} = P_h + P_e$$

Core Loss is given in manufacturer's data sheets for each specific core material as P_{core} vs B_m curves in log. scale, with operating frequency as a parameter:

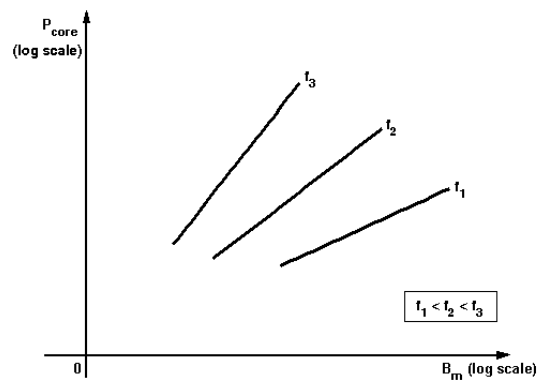

Core loss increases with increasing frequency